

閥類型符號 SYMBOL

PRCV-※

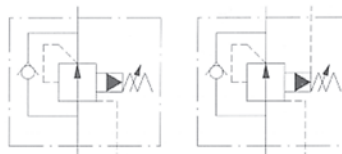

規格說明 SPECIFICATION

型式 MODLE		最高使用壓力 MAX. PRESSURE (kgf/cm ²)	壓力調整範圍 PRESSURE ADJ. RANGE(kgf/cm ²)	流量 RATED FLOW l/min	重量 WEIGHT kg	
管式安裝 THREADED CONNECTIONS	板式安裝 SUB-PLATE MOUNTING					
PRCV-T03-※	PRCV-G03-※	250	1 : 7-70	50	4.9	5.5
PRCV-T06-※	PRCV-G06-※		2 : 7-140	125	8.4	8.7
PRCV-T10-※	PRCV-G10-※		3 : 7-210	250	17	15

型號說明 HOW TO ORDER :

PRCV-G 06-1-10

- ① ② ③ ④ ⑤

① 單向減壓閥 PRESSURE REDUCING AND CHECK VALVE

② 安裝方式 MOUNTING

G : 板式安裝 SUB-PLATE MOUNTING
T : 管式安裝 THREADED CONNECTIONS

③ 閥規格 VALVE SIZE

03 : 3/8" 06 : 3/4" 10 : 1-1/4"

④ 調壓範圍 PRESSURE ADJUSTING RANGE

1 : 7 - 70 kgf/cm² 2 : 7 - 140 kgf/cm²
3 : 7 - 210 kgf/cm²

⑤ 設計編號 DESIGN NUMBER

附屬品 ATTACHMENT :

型式 MODLE	安裝螺絲 SOC HOL CAP SCREW
PRCV-G03	M10 × 70L.....4pcs
PRCV-G06	M10 × 80L.....4pcs
PRCV-G10	M20 × 95L.....6pcs

測試條件 PERFORMANCE CURVES:

測試油黏度 TEST FLUID VISCOSITY : 35 cST

測試油溫度 TEST TEMPERATURE : 50°C

PRCV - T06 、 PRCV - G06

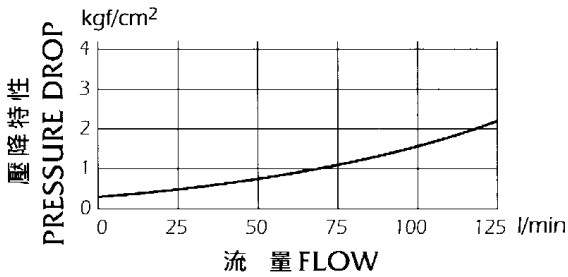

PRCV - T03 、 PRCV - G03

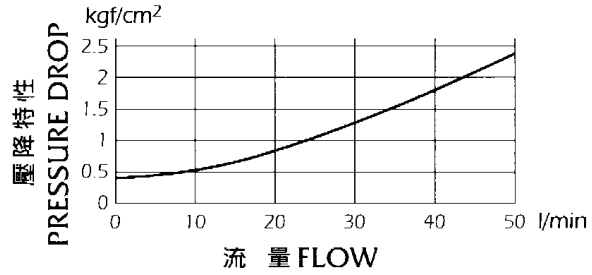

PRCV - T10 、 PRCV - G10

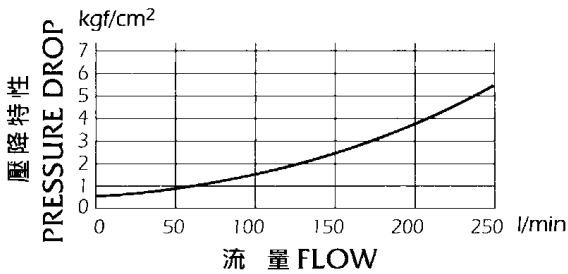

安裝尺寸 INSTALLATION DIMENSIONS:

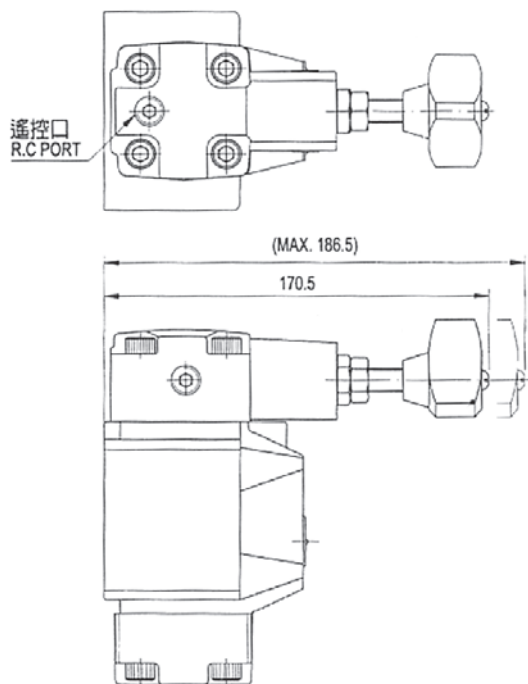

PRCV - G03

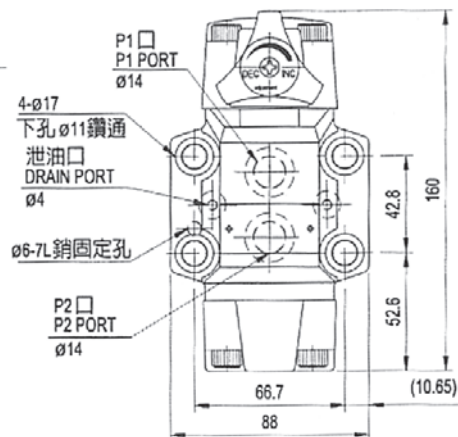

安裝尺寸 INSTALLATION DIMENSIONS:

PRCV - G06

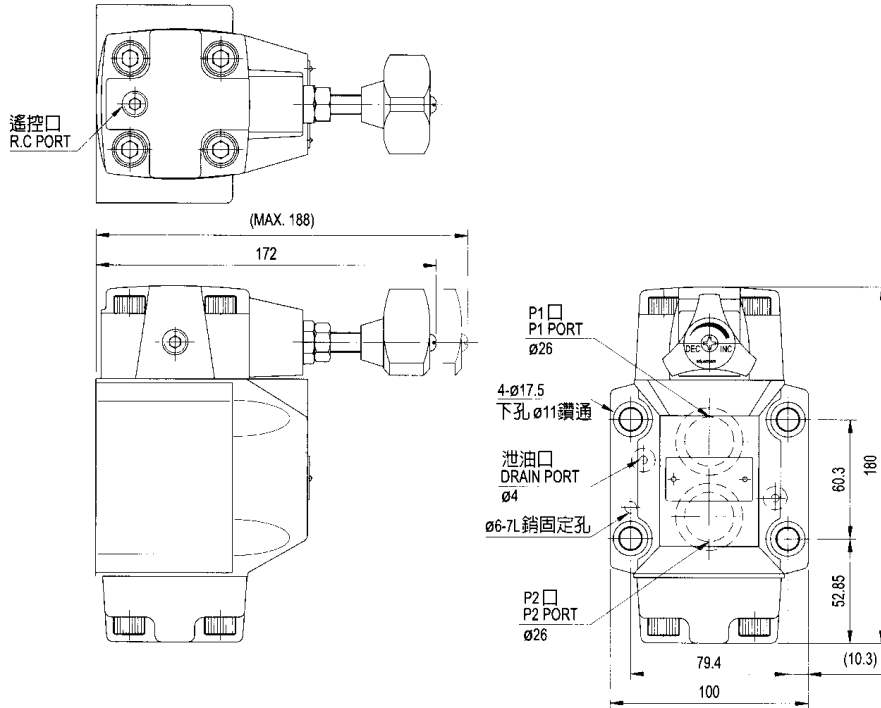

PRCV - G10

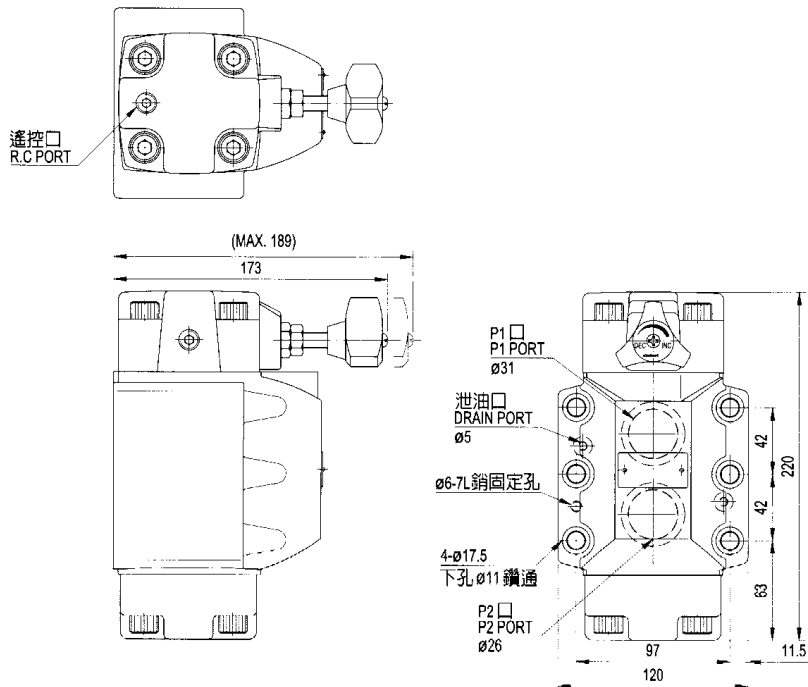

安裝尺寸 INSTALLATION DIMENSIONS:

PRCV - T03

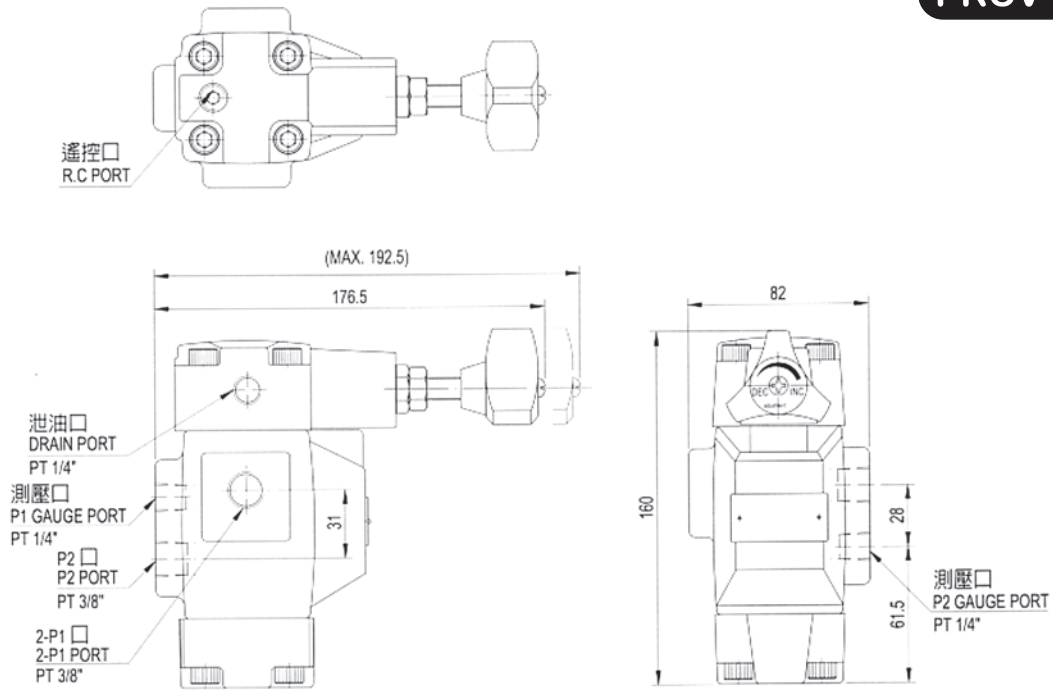

PRCV - T06

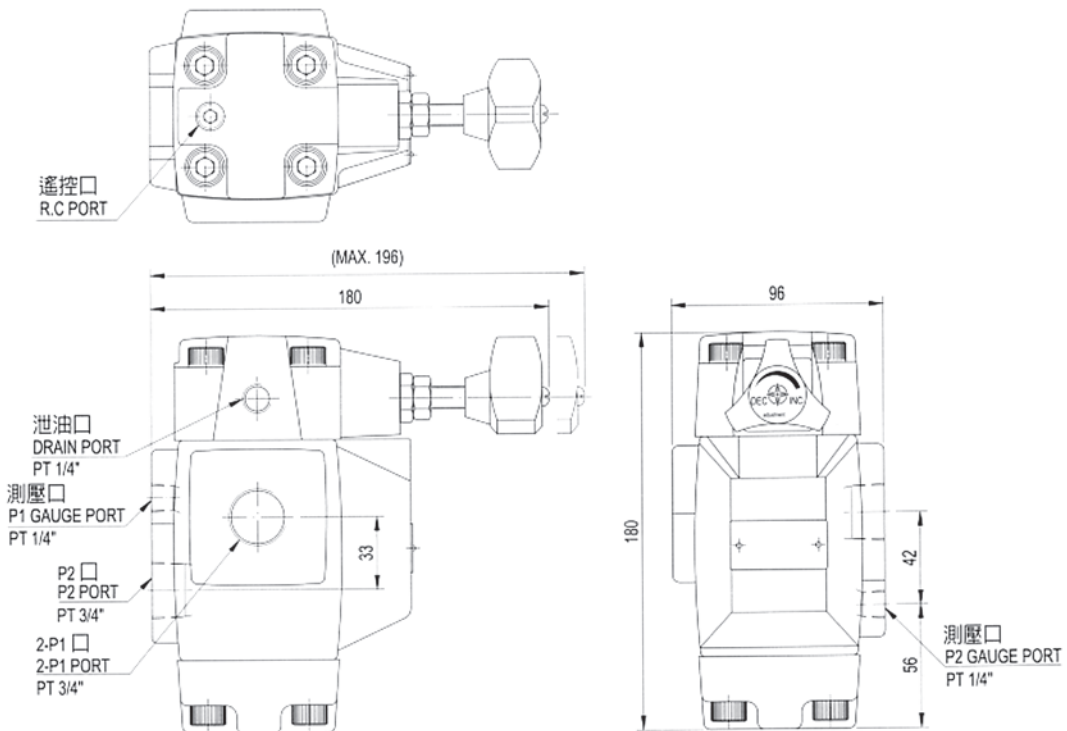

安裝尺寸 INSTALLATION DIMENSIONS:

單位 UNIT : mm

PRCV - T10

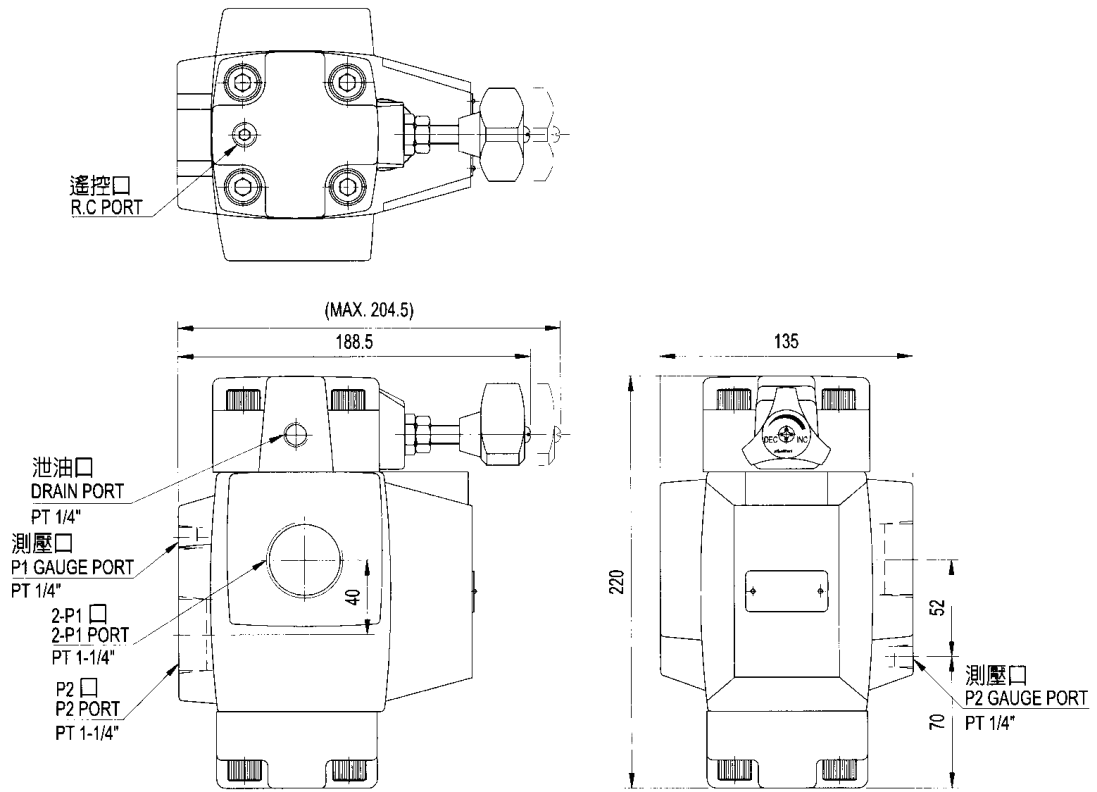

安裝尺寸 INSTALLATION DIMENSIONS

PRCV - G03

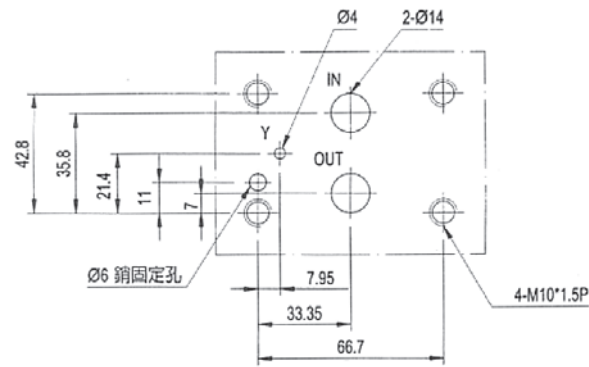

PRCV - G06

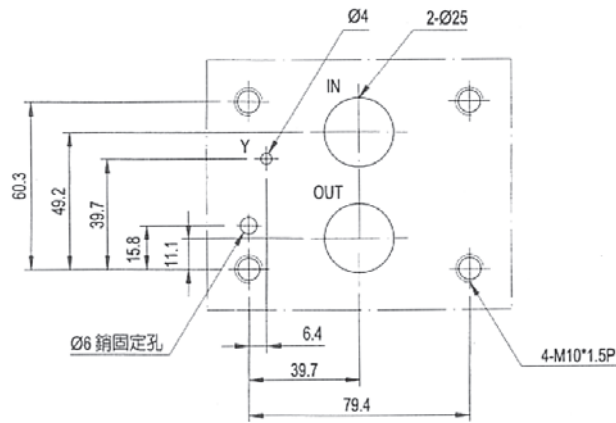

PRCV - G10

