



閥類型符號 SYMBOL

PRV-G ※

PRV-T ※



規格說明 SPECIFICATION

型式 MODLE		最高使用壓力 MAX. OPERATING PRESSURE (kgf/cm ²)	壓力調整範圍 PRESSURE ADJ. RANGE kgf/cm ²	流量 RATED FLOW l/min	重量 WEIGHT kg	
管式安裝 THREADED CONNECTIONS	板式安裝 SUB-PLATE MOUNTING					
PRV-T03-※	PRV-G03-※	250	1 : 7-70	50	4.4	4.9
PRV-T06-※	PRV-G06-※		2 : 7-140	125	7.5	7.2
PRV-T10-※	PRV-G10-※		3 : 7-210	250	12.2	12.2

型號說明 HOW TO ORDER :

PRV-G 06-1-10

- ① ② ③ ④ ⑤

① 減壓閥 PRESSURE REDUCING VALVES

② 安裝方式 MOUNTING

G : 板式安裝 SUB-PLATE MOUNTING
T : 管式安裝 THREADED CONNECTIONS

③ 閥規格 VAVLE SIZE

03 : 3/8" 06 : 3/4" 10 : 1-1/4"

④ 調壓範圍 PRESSURE ADJUSTING RANGE

1 : 7 - 70 kgf/cm² 2 : 7 - 140 kgf/cm²
3 : 7 - 210 kgf/cm²

⑤ 設計編號 DESIGN NUMBER

附屬品 ATTACHMENT :

型式 MODLE	安裝螺絲 SOC HOL CAP SCREW
PRV-G03	M10 × 55L.....4pcs
PRV-G06	M10 × 55L.....4pcs
PRV-G10	M20 × 55L.....6pcs

測試條件 PERFORMANCE CURVES:

測試油黏度 TEST FLUID VISCOSITY :35 cST

測試油溫度 TEST TEMPERATURE : 50°C

PRV - T03 PRV - G03

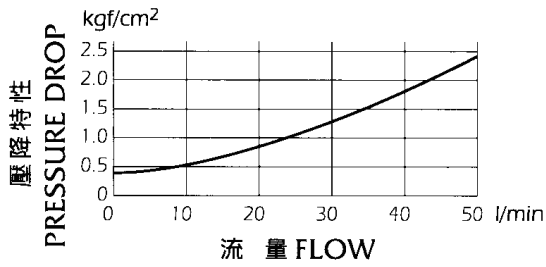

PRV - T06 PRV - G06

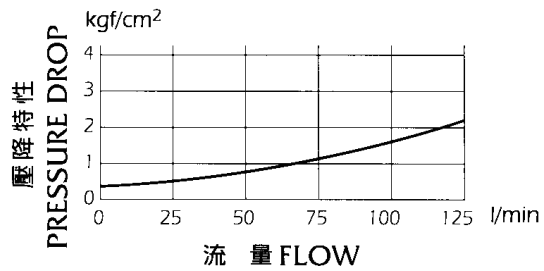

PRV - T10 PRV - G10

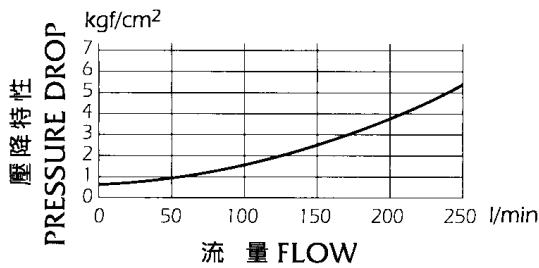

安裝尺寸 INSTALLATION DIMENSIONS:

PRV - G03

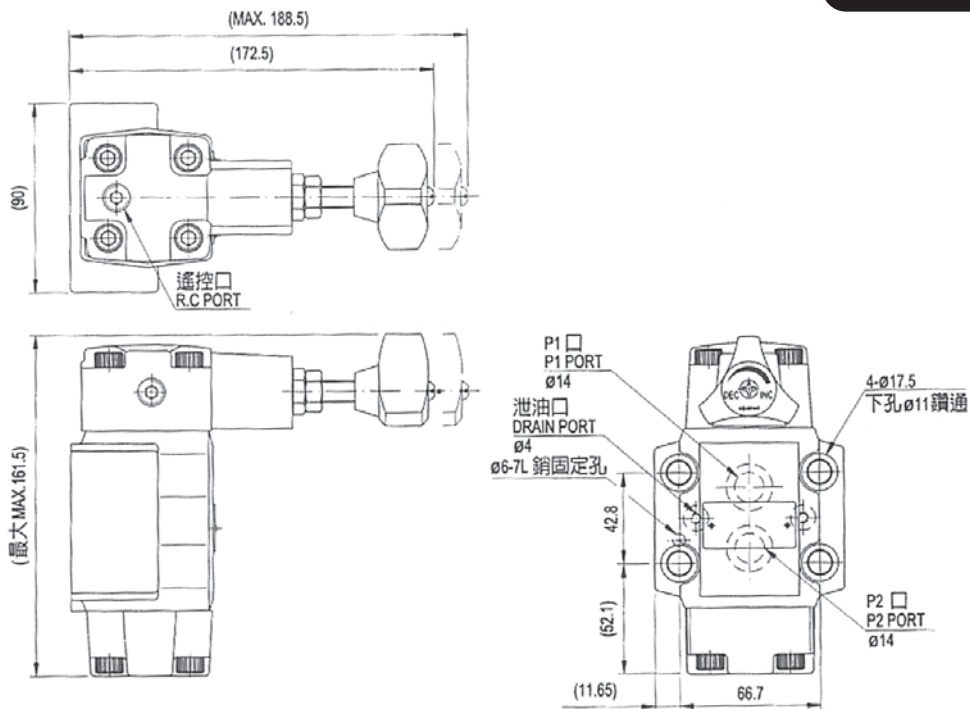

安裝尺寸 INSTALLATION DIMENSIONS:

PRV - G06

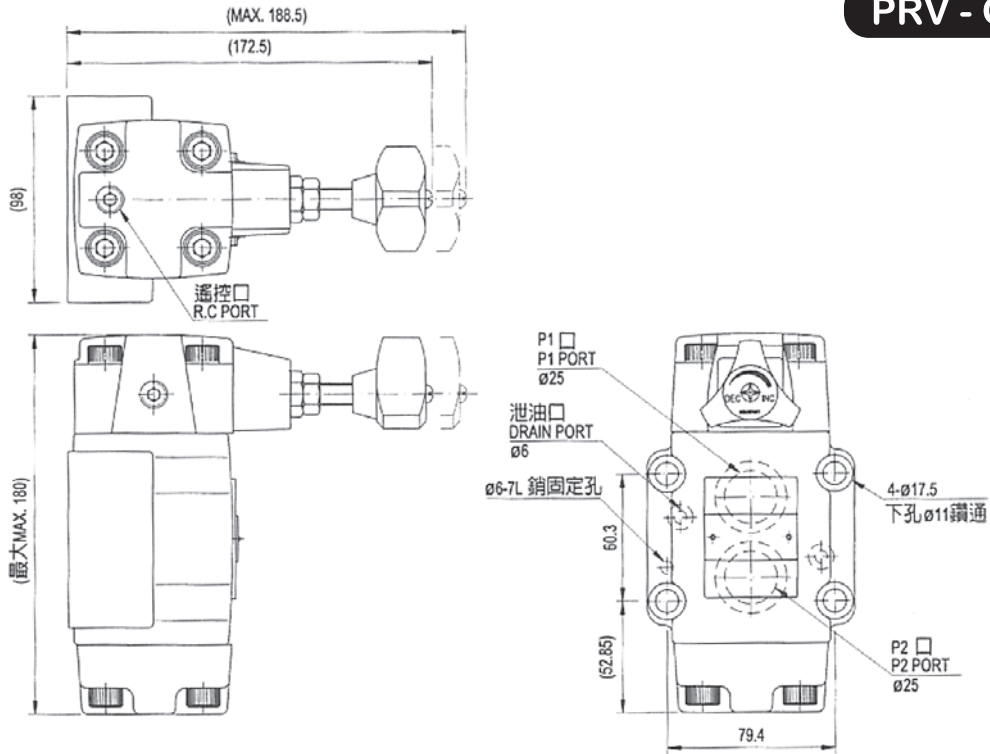

PRV - G10

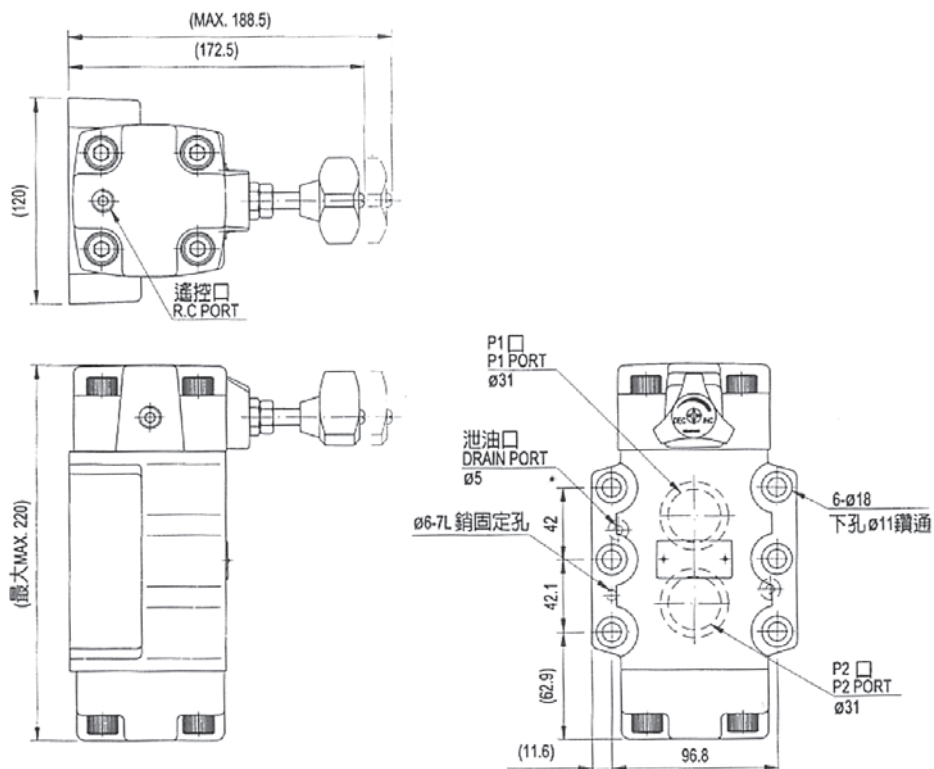

安裝尺寸 INSTALLATION DIMENSIONS:

PRV - T03

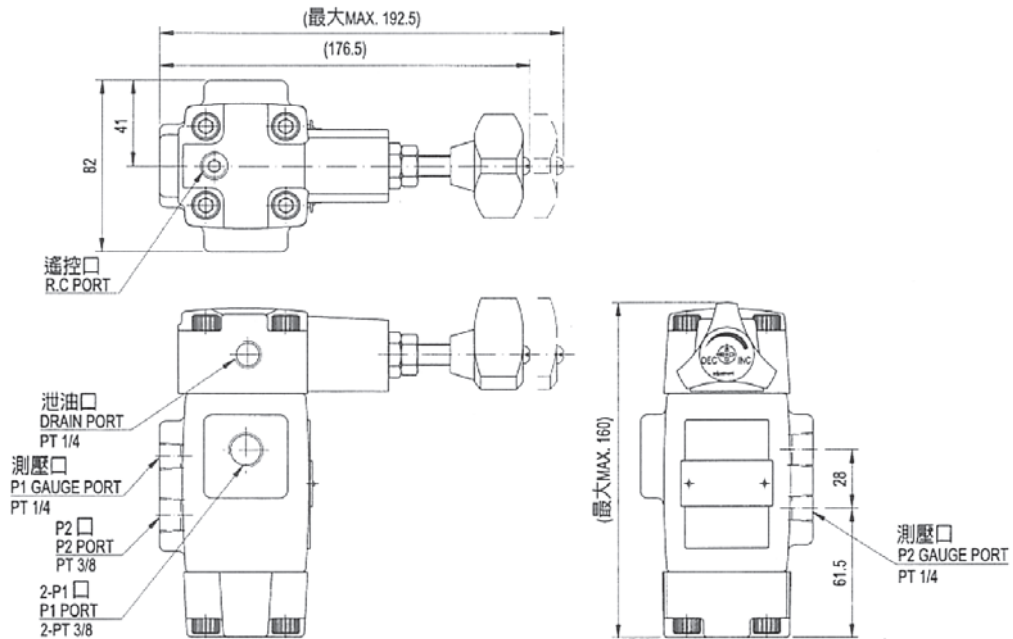

PRV - T06

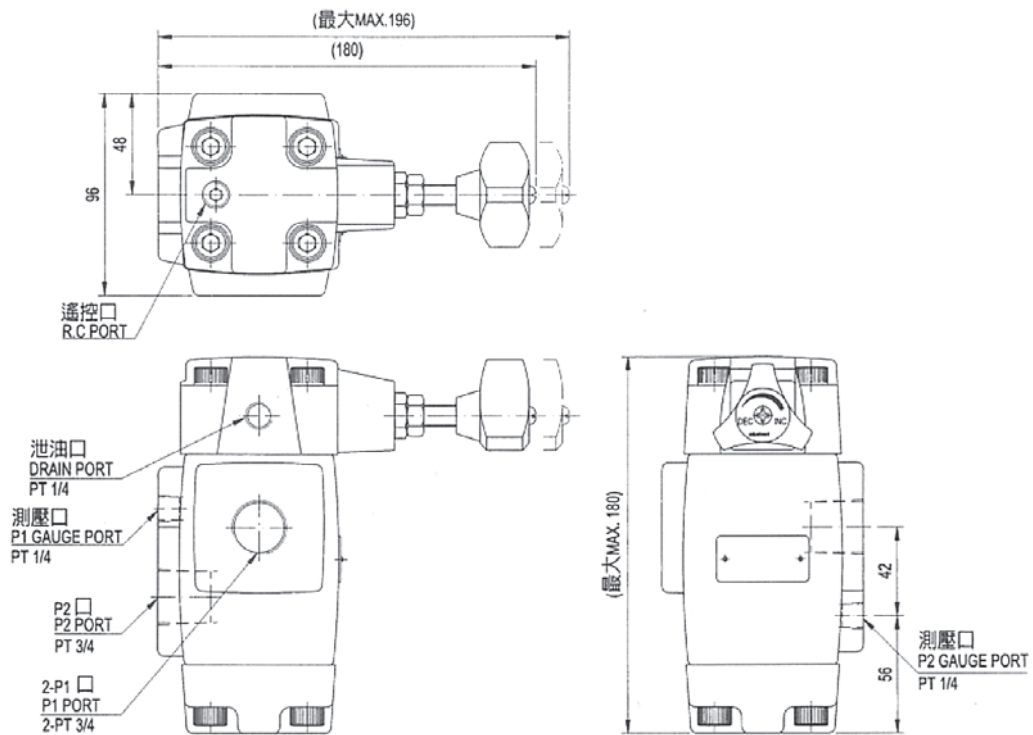

安裝尺寸 INSTALLATION DIMENSIONS:

PRV - T10

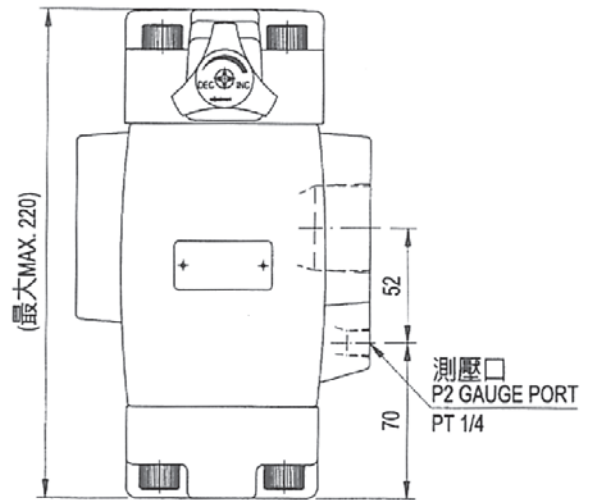
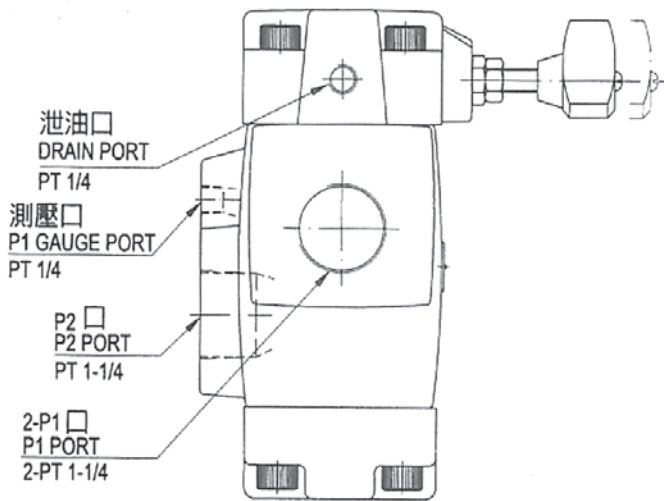
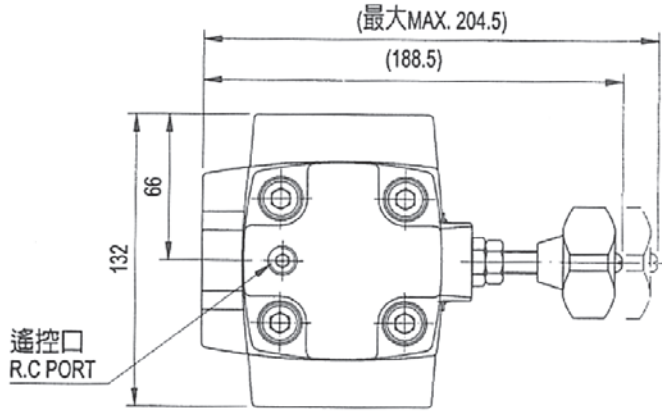

安裝尺寸 INSTALLATION DIMENSIONS:

PRV - G03

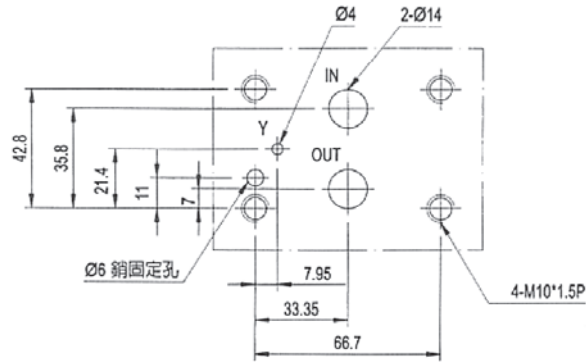

PRV - G06

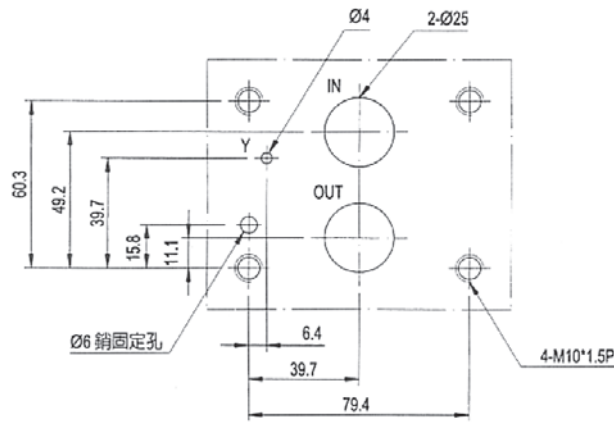

PRV - G10

